

ANTHONY SERVICE-FREE "AC-SERIES" CONVENTIONAL LIFTGATES

**MODELS
AC-1600-SF
AC-2000-SF
AC-2500-SF**

ATTENTION!

The success or failure of this equipment could very well depend on a thorough and proper installation. **Read and understand** the contents of these instructions before proceeding.

IMPORTANT!

When installed this lift must not alter, or prevent, vehicle compliance to any existing state or federal standards, and especially FMVSS 105. Each chassis manufacturer's recommendations should be consulted for compliance.

Fill out and mail in the Warranty Card to validate warranty on unit.

NOTE TO INSTALLER!

Read operating instructions and maintenance guide before installing unit to familiarize yourself with its operation.

ATTENTION!

INSTALLATION INSTRUCTIONS

INTRODUCTION

EVEN THOUGH THE FOLLOWING GOES WITHOUT SAYING, WE FEEL COMPELLED TO STATE...

Anthony lifts should only be installed by those with sufficient basic skills to understand the installation and operation of the lift, along with the equipment on which the lift is being installed. These installation instructions are not intended to give rationale for all installations that are given; however, it is the intent of these instructions to give the installer both the operations and what we believe to be the most desirable sequence of implementing these operations. These instructions can in no way expand into an area where they will replace a qualified person, or clear thinking and a basic knowledge that must be possessed by the installer.

We urge the installer (or anyone else) to call us if they have any questions. We have qualified personnel at our Pontiac, IL plant to answer any questions that you may have. A detailed discussion on the phone is a far more satisfactory than a detailed written explanation.

It has been our experience that a knowledgeable journeyman following the installation instructions and observing the operation of the lift will have sufficient comprehension of the lift to enable this person to troubleshoot and correct all normal problems that may be encountered. However, again we urge you to call us at the Pontiac, IL plant if you find the lift not operating properly or if you do not know how to make the necessary repair, or have any doubts or questions...

**Anthony Liftgates, Inc.
1037 West Howard St.
Pontiac, IL. 61364
815-842-3383**

Notice! Unit must be installed according to installation instructions or warranty will be void. If any deviation is deemed necessary, written permission must first be obtained from the manufacturer.

STEP 1. ASSEMBLE THE PLATFORM TO THE LIFTGATE MECHANISM

Remove the long pin, in the liftgate mechanism, from the radius arms, cam plates and springs. Before beginning, take note on how the pin is currently installed through the above mentioned items as this will aid you when re-assembly.

Hang the platform from a hoist, or chain, as shown. Install an eye bolt through the $\frac{3}{4}$ " hole in the platform. Then, install a "C-clamp" onto the platform ramp in the center. Thread the lifting chain through the "C-clamp" and over to the eyebolt. Hook to the eyebolt. You should now be able to lift the platform and have it stood up straight.

Position the platform up to the liftgate mechanism. Align the platform hinge plates with the liftgate "radius arms" and "cam plates". Re-install the pin through the hinge plates, arms and cam plates as well as the assist springs.

Note: A combination of springs (large wire diameter and small wire diameter) is used to assist the opening & closing of the platform. The combination of springs depends on the platform size and weight. Be certain these springs are re-installed on the same liftgate.

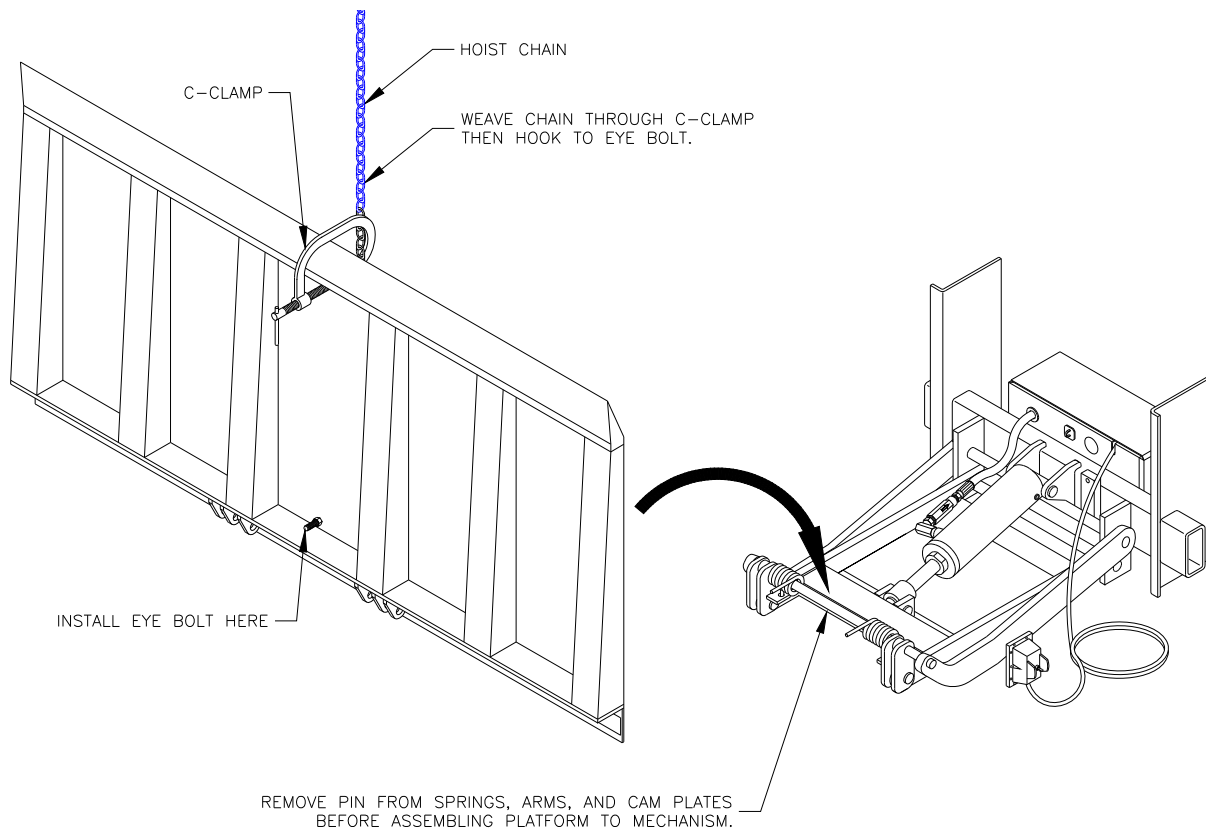

STEP 2. PREPARE THE PLATFORM & MECHANISM FOR MOUNTING

Unfold platform so that the diamond plate surface is facing upward. Replace the “shipping plug” in the top of the power pack reservoir with the “breather cap” (supplied).

Note: *Certain models may already have a leak-proof breather cap in place, if so equipped, it's not necessary to replace the shipping plug (Fenner brand).*

Unfold gate as shown.

Replace plug in reservoir with “breather cap” supplied (if necessary).

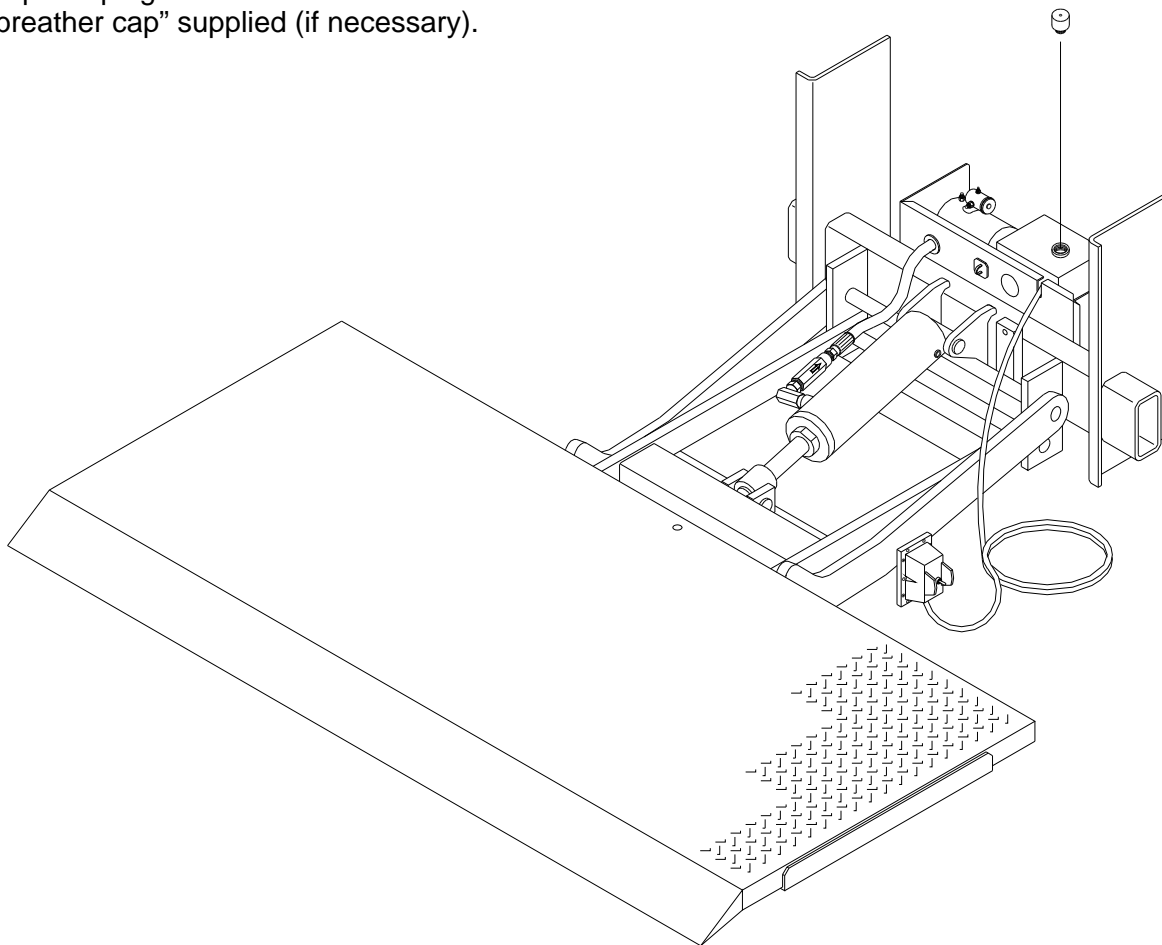

STEP 3. HANGING THE PLATFORM & MECHANISM AGAINST THE TRUCK REAR SILL.

The liftgate platform & mechanism will be spaced 1" minimum away from the "trucks rear sill". This clearance is needed to fold the platform. (1" thick spacers provided by installer)

Using a hoist, raise liftgate platform & mechanism up to the "truck rear" and position the liftgate bolster (*front edge of platform*) up to the trucks rear sill.

Center the platform, left to right of the truck, then clamp 3 to 4 ft. long heavy parallels, (provided by installer) to the platform, as shown. Parallels should extend into the truck body floor, and are intended to keep the load area of the platform parallel to the truck floor. *Parallels should be of heavy material, such as 3" x 3" x 1/4" steel angle iron minimum.*

Caution! We recommend that the hoist, forklift, (*or other device used to raise the liftgate into position*), be kept in place for safety purposes while completing installation.

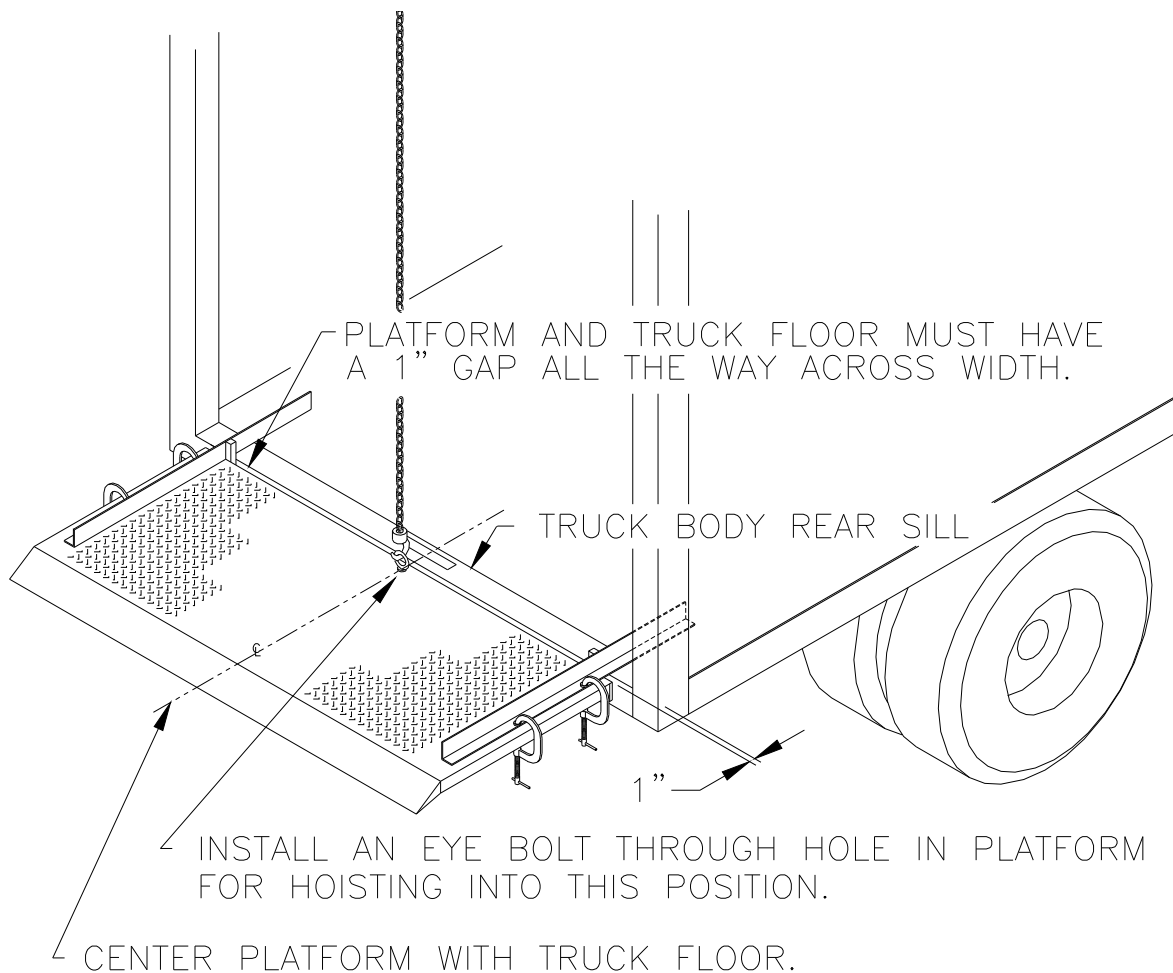

Caution! NEVER GET UNDER LIFTGATE while installing or painting unit. Work so that you would be **clear** of any falling objects in case the clamps, hoist, weld, etc. should fail.

STEP 4. CUT-OFF SWITCH/CIRCUIT BREAKER INSTALLATION & POWER CABLE ROUTING

- a) Attach the Circuit Breaker Bracket (*with circuit breaker*), as near the vehicle battery(is) as possible (within two feet). Location should be easily accessible for resetting, and **decal** on bracket must be **clearly visible**, as well as, provide protection against anything contacting terminals and causing an electrical short. If a “Solenoid Cut-off switch” is supplied, mount it near the circuit breaker bracket. If a “Solenoid Cut-off” switch is supplied, it can be wired either into the ignition (key switch) of the vehicle, or to a separate toggle switch mounted in the dashboard of the vehicle.
- b) Place one end of the “power cable” (30 ft.) through a hole in the end panel of the “liftgate power pack enclosure”, then connect it to the solenoid post (marked “BAT”) on the liftgate power pack. **Note: Be sure to use a backup wrench to hold the inner nut on the “solenoid post” while tightening to prevent “stud” from turning inside solenoid.** Route the “power cable” along the vehicle “frame rails” toward the front of the vehicle, to the circuit breaker. Use plastic “wire ties” provided to secure cable, secure and support wiring at intervals no greater than 18 inches. Connect the remaining cable end to the circuit breaker (50 in. lbs. torque max. on circuit breaker).
- c) Connect the short (2 ft.) cable, to the other terminal of the circuit breaker, then to the vehicle 12 volt battery (is) positive (+) terminal. Connection can be made to the HOT side of “engine starter solenoid” instead of the battery, if so desired.

Notes: a) On trailer installations if an auxiliary “liftgate battery bank” is going to be used, it is recommended to have an additional 150 AMP circuit breaker just ahead of the liftgate “battery bank”, this will protect the charge cable that articulates at the nose of the trailer. Contact the factory for more information.
 b) On “trailer” installations, route the cable through holes with grommets in crossmembers, or through “ducting” sometimes used on trailers.
 c) If battery(is) is grounded to engine, make sure engine is grounded to the chassis frame with at least 2 gage wire, or larger. If not, add a 2-gage ground wire from engine to chassis.

CAUTION! Never secure cable in such a way that it comes in contact with other wiring, fuel lines, fuel tank, brake lines, air hoses, exhaust system, etc. Keep all wiring from contacting sharp edges, such as, edges of “vehicle frame rails”.

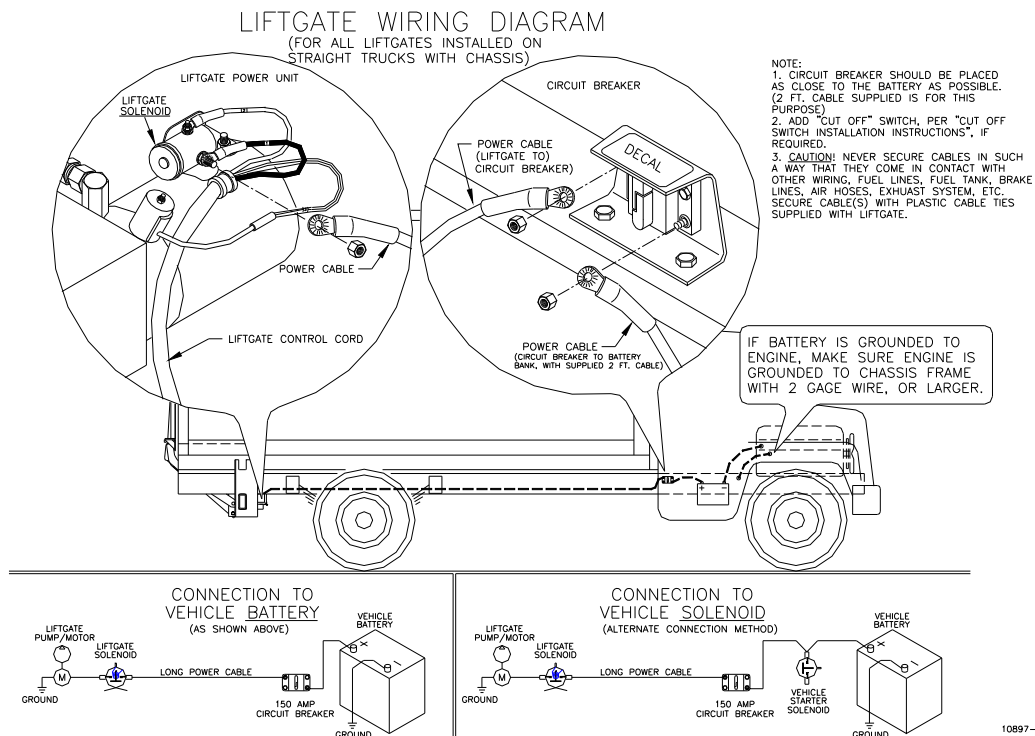

STEP 5. POSITION ADAPTER FRAME

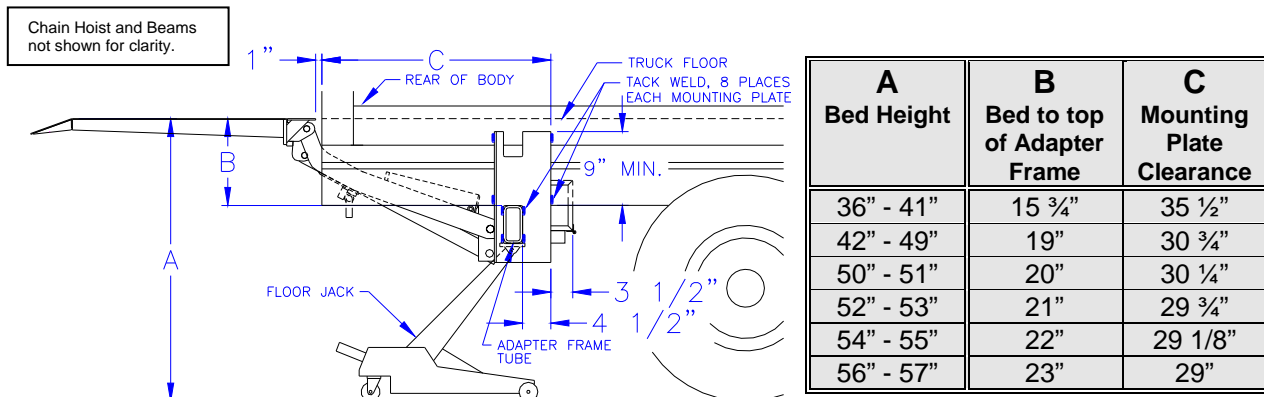

Note: Dimensions are for reference. The basic idea is to position the “adapter frame” as high as possible, (*this may mean it will touch the bottom of the chassis frame rails*), while keeping the 3” x 6” tube approximately vertical, and having at least 1/4” of chrome piston rod extended from the lift cylinder. Keeping that in mind proceed as follows.

Position the Adapter Frame Tube (3” x 6” tube) to attain the dimensions shown in the table. Slide the “mounting plates” over the Adapter Frame Tube. The wide side of the “mounting plates” goes toward the front of the vehicle. The mounting plates can be trimmed in length, off the top, if necessary, as long as 9” min. of contact area is maintained between the plate and the chassis & body long sills (as shown).

The Adapter Frame must be positioned so that when the platform is at truck floor level, the lift cylinder is extended at least a 1/4”. This can be determined quickly by looking at the amount of “chrome piston rod” showing on the lift cylinder, you should see at least 1/4” of chrome, (*more on lower bed height installations*). Note: This may require the “mounting plates” to be slightly “tilted”, forward or backward. The “tilt” does not affect the function of the liftgate. This 1/4” of cylinder extension allows the platform to continue to raise to the “truck floor” level, even after the liftgate has been in service for a long time.

THE FOLLOWING IS ONE METHOD OF POSITIONING THE ADAPTER FRAME.

Position the mounting plates over the ends of the 3” x 6” adapter frame tube, and with the power cable connected, move the “control” switch to the DOWN position. Then, pull on the mounting plates until the “mounting plates” are approximately straight up & down (a “come-along” may be of help). Continue to raise up the adapter frame with a floor jack until it is in position (this position is often up against the bottom of the chassis frame).

Power Down models can usually power themselves into position without the aid of a “floor jack” or “come-along”. Once power is connected to the liftgate, the “control” can be used. The functions will be opposite from the way they read on the “control box”, this is because the platform is clamped stationary.

Position the “mounting plates” around each end of the “adapter frame tube” and up against the truck chassis. Once the liftgate mechanism is in position, tack weld in places shown in the illustration, (tack welds must be 3/8” fillets x 1” long minimum).

- * - The “adapter frame tube ends” must be tack welded four places around each of the “mounting plates”.
- * - The “mounting plates” must be tack welded, near the top, to the “chassis frame rails” and “body long sills” (four places on each).

STEP 6. TESTING INSTALLATION BEFORE FINAL WELDING OF MECHANISM

Caution! While performing this step, stand clear of area that the liftgate travels at all times in the event that a failure would endanger you!

Remove clamps from platform. Then, begin lowering the platform; by depress the control switch to the DOWN position to “lower” the platform to the ground. (*Note: Keep the hoisting device attached to the platform for safety, lower the hoisting device just ahead of the platform as it lowers*). The liftgate should be bearing the full load of the itself now. Depress the control switch to the UP position to “raise” the platform to bed level. Once the liftgate platform travels the full UP, DOWN cycle, smoothly (from truck floor level to the ground, then back up to the truck floor level again), weld the unit complete, as *described below. Remove the hoisting device and floor jack once welded.

If liftgate platform does not travel full cycle correctly, replace clamps and hoisting device, remove tack welds, then reposition per STEP 4, then re-test. Repeat as necessary.

* = Weld liftgate while platform is lowered to the ground, **not** in raised position. **Shield** the lift cylinder chrome piston rod, and hoses, to prevent damage by weld spatter. Apply 3/8” fillet welds throughout.

PLATFORM LEVEL ADJUSTMENT PROCEDURE:

If necessary, adjustment can be made to reposition the platform attitude with the truck floor. **The platform should be between “level” and “3/4 inch higher” at the rear edge to allow for deflection when loaded.** Shims (approx. size 1/16” thick, 3/4” x 2 1/4” long) can be installed between “cam plates” and the “ platform” after installation is complete (weld shims to cam plates).

IMPORTANT! Add to truck frame to achieve 9” minimum of vertical contact between “liftgate mounting plates” and “truck frame”.

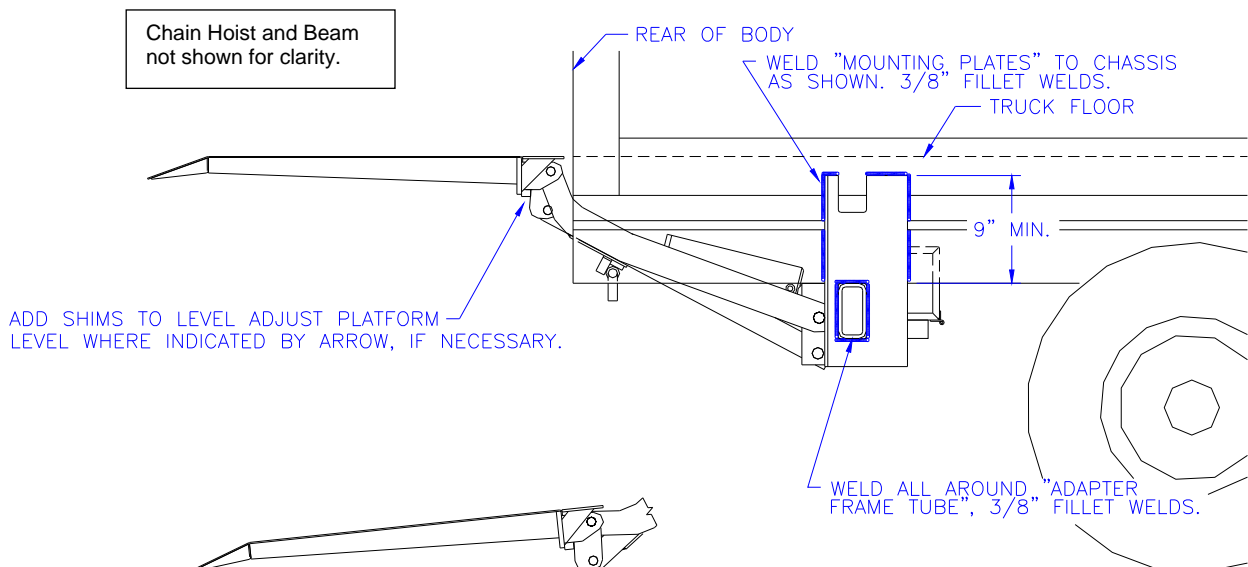

STEP 7. MOUNT THE “UP STOP” BAR

- a) Raise the platform to truck floor height. Platform must be flush with the truck floor, NOT above or below. While maintaining the 1” gap between the platform and truck rear sill.
- b) Measure the distance between the frame rails or body long sills. Take the measurement where the “up stop” will line up when its positioned against the “liffframe” near the liffframes cross tube (as shown below).
- c) Mark and cut the “up stop” bar the same as the measurement just taken. Cut an equal amount from each end of the longer tube on the “up stop” bar.

The “Up Stop” is used to stop the liftgate when the platform reaches the truck floor.

The “Stop Bar” weldment should be welded in place between the frame rails of truck chassis. The liftgate “liffframe” contacts it to act as an “up stop” at the floor level.

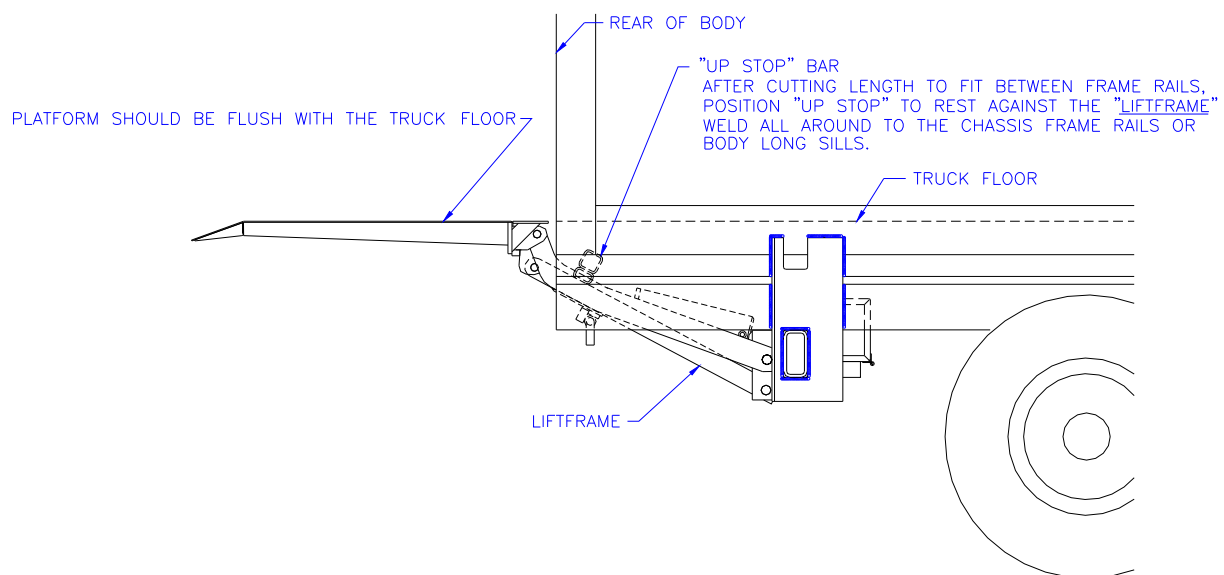

STEP 8. MOUNTING THE “IN TRANSIT” LATCH BLOCK

Fold and raise the liftgate platform into the upright, stored (in transit) position. Rotate & slide the "latch pin", across the "radius arm". The "latch pin" is located on the underside of the "liftframe", Position the "latch block" 1/32" -1/16" away from the top side of the "latch pin" while having the long edge of the block against the bottom side of the "radius arm". Weld the "latch block" to the "radius arm" using 1/4" fillet welds. Weld all around the "latch block".

Note: The Latch is for "in transit" locking of the tailgate only! **DO NOT** attempt to set the "latch pin" with the platform unfolded, and raised.

Operation of latch:

Rotate & slide the latch pin toward the **right** to **disengage** (unlatch).

-Or-

Rotate & slide the latch pin toward the **left** to **engage** (latch).

Note: When welding, be certain to attach the "welding ground clamp" to the radius arm that you're welding. Otherwise "grounding could occur through the hydraulic hose."

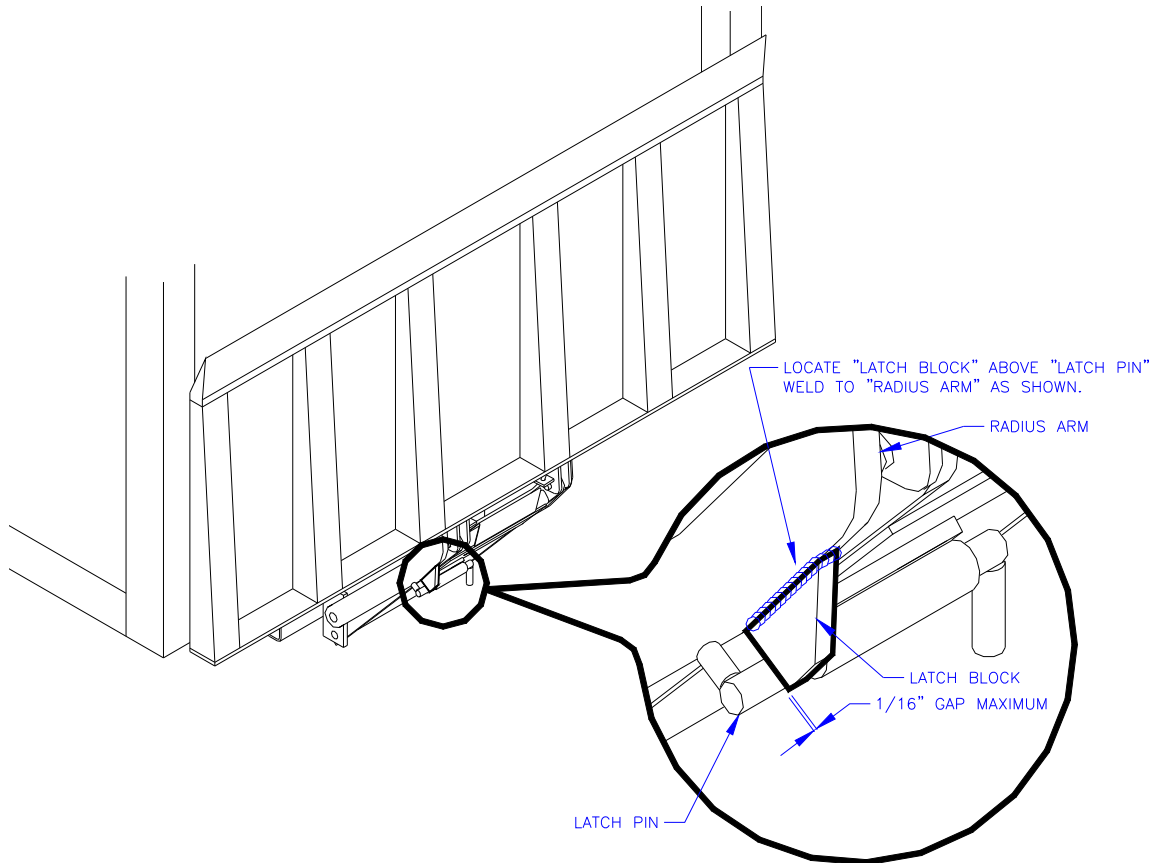

STEP 9. MOUNT THE LIFTGATE CONTROL STATION(S)

The “control station” is intended to be mounted at a convenient height, accessible while the operator is standing on the ground, clear of the platform, and when standing inside the vehicle body. A common location for vans is on the rear face of the curbside “rear corner post” of the vehicle body (must be clear of the platform when folded), at approx. 1 1/2’ to 3’ above the vehicle floor.

On “flat bed” applications where there is no corner post, a few alternative locations, among others, are:

1. Under the underside of the bed (this requires you to make a custom bracket to be mounted to the bottom of the body crossmembers and which should provide shielding to the control.
2. Use a Removable, Hand Held Control. (*these can be purchased from Anthony Liftgates, Inc.*)
3. Use a Flush Mount Control then recess it into the side of the body *frame* (*these can be purchased from Anthony Liftgates, Inc.*).

Note: There are other optional “control stations” available that may fit the application better (depending on the application). A few are:

- **Dual, Streetside Control** - (this is a second surface mounted control station)
- **Flush Mount Control** - (this is a switch mounted in a recessed cup in the side, rear, or the inside of the vehicle lining)
- **Removable, Hand Held Control** - (this is a hand held control that will allow the operator to move around and keep a safe distance from the liftgate, this can also be removed and stored away from the liftgate).

STEP 10. ATTACH CHAIN & STAPLE ASSEMBLIES

The “chain & staple assemblies” are used to hold the platform in an upright position during transit.

- a) Fold the platform to an upright, straight up & down position. There should be approx. a 5/8” space between the platform and the truck body when folded. A filler board, or rubber bumper can be added to fill this space if desired.
- b) Position one “staple” onto each end of the liftgate platform as high as possible on the platform channel. The person operating the liftgate must be convenient to reach while standing on the ground. Tack weld in place.
- c) Position one “chain & staple assembly” onto each side of the truck body. This location needs to be straight across from the “staple” just tacked onto the platform. Position the large link of chain over the “staple” then insert the hook through the bottom of the staple. Then, position the “staple”, which is attached to the chain, onto the truck body. Make sure the chain is taught. Tack weld to the truck body.
- d) Test the operation of the “chain & staple assemblies”. Unhook and re-hook both “chain & staple assemblies”. Weld all around the four “staples” (two on the platform and two on the body).

Note: If liftgate is being mounted on a “flat bed” (platform body) without corner posts, then a structure should be built onto the body to act as “corner posts” so that chain & staple assemblies can be attached.

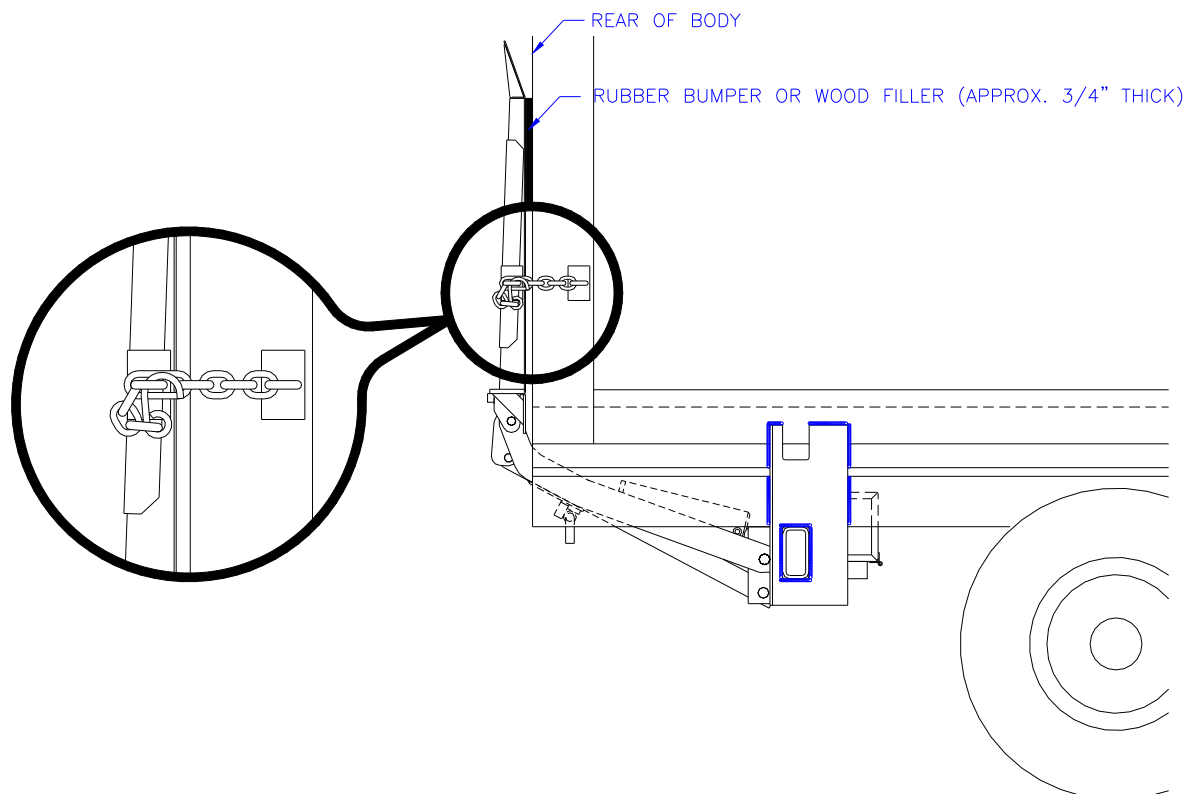

STEP 11. APPLY DECALS

Warning! All decals must be in place and legible at all times. For replacement contact:

Anthony Liftgates, Inc.
1037 W. Howard St.
Pontiac, IL. 61764
Ph: 815-842-3383

Anthony "AC-Series" Conventional Liftgate Decal Placement Diagram

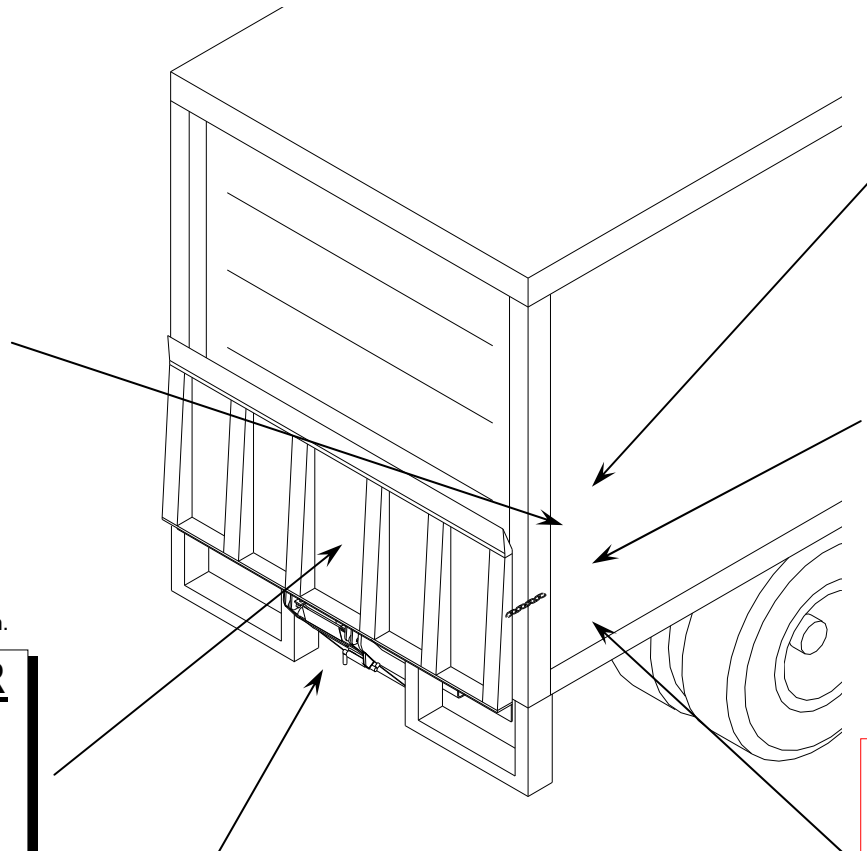

("Circuit Breaker" decal)
Place on side wall of body.

NOTICE

THIS LIFTGATE IS PROTECTED WITH AN ELECTRICAL OVERLOAD CIRCUIT BREAKER, LOCATED NEAR THE POWER SUPPLY.

IF THE BREAKER TRIPS, CONTACT A QUALIFIED MECHANIC BEFORE RESETTNG.

("Stand Clear" decal)
Place on bottom side of platform.

STAND CLEAR

DO NOT RIDE ON LIFT

("Secure Latch" decal)
Place next to "Latch Pin" on under side of lifframe.

SECURE LATCH WHILE IN TRANSIT

←

("Operating" decal)
Place on side wall near control.

("Maximum Capacity" decal)
Place on lifframe.
Check model for correct capacity.

1600 lb.

MAXIMUM CAPACITY

("Urgent Warning" decal)
Place on outside rear corner.

URGENT WARNING

ELEVATING GATE INSTRUCTIONS

Before Operating LIFT, Be Sure You Understand

1. Improper operation of this lift can result in serious personal injury. Do not operate unless you have been properly instructed and have read and are familiar with the operating instructions. If you do not have a copy of the instructions please obtain them from your employer, distributor, or lessor, as appropriate, before you attempt to operate the lift.
2. Be certain the vehicle is properly and securely braked before using the lift.
3. Always inspect this lift for maintenance or damage before using it. If there are signs of improper maintenance, damage to vital parts, or slippery platform surface, do not use the lift. Do not attempt your own repairs, unless you are specifically trained.
4. Do not overload. See Mfg. Literature and/or Rating Label on the unit for the rated load. Remember that this limit applies to both raising and lowering operations.
5. Each load should be placed in a stable position as near as possible to the center of the platform.
6. Never stand in or move through or allow anyone else to stand in or move through the area in which the lift may operate or into which an upset load might fall.
7. This is not a passenger lift. Do not ride the lift with unstable loads or in such a manner that failure would endanger you. The lift is not equipped with a back-up system to prevent falling in the event of a failure.

OPERATING INSTRUCTIONS

ANTHONY RAIL LIFTGATE

For "AC" Series Conventional Liftgates

OPEN PLATFORM TO HORIZONTAL POSITION.

- A. Unlatch the "latch pin", near the center of the lifgate mechanism, by twisting, then sliding it past the "latch block" welded to the radius arm.
- B. Remove the "hook and chain" from each side of the platform, streetside first.
- C. Unfold the platform, by pulling back on the platform, until in horizontal position (this is done manually).
- D. Press the "Down" switch, on the control, to lower the platform.
- E. Press the "Up" switch, on the control, to raise the platform.
- F. Load and unload cargo with the platform at either the truck floor level or the ground. Repeat step D and E to raise and lower cargo.

STORING PLATFORM FOR TRANSIT.

- A. Raise the platform to truck bed level.
- B. Fold the platform, by lifting up on the platform, until it's in the vertical position (this is done manually).
- C. Reattach the "hook and chain" on each side of the platform, outside first. Slip the large link of chain over the "base" on the platform. Then insert the hook through the "latch". The hook should go through the bottom of the angle first.
- D. Set the "latch pin" by twisting, then sliding it past the "latch block" welded to the radius arm near the center of the lifgate.

Note: If liftgate has a "Main Power Cut-off Switch" be certain to turn it "OFF" when not in use to prevent unauthorized use!

Anthony Liftgates, Inc. 1037 W. Howard St. Pontiac, IL 61764

STEP 12. MOUNT LIGHTS & LICENSE PLATE

All lighting must be in accordance with FMVSS 108.

In most cases, the taillights and license plate can be left in the place they were in before the liftgate installation began, provided the liftgate doesn't interfere, or block there function.

An option for placement of the taillights is on the ends of the liftgate "adapter frame tube" (6" x 3" tube).

STEP 13. INSTALL REAR UNDERRIDE PROTECTION.

The installation must comply with current "rear underride protection" regulations for the appropriate type vehicle.

STEP 14. CHECKING THE UNIT OPERATION

1. Make sure the liftgate platform will travel a complete cycle, Up and Down, smoothly and freely, with platform completely unfolded.
2. Make sure the liftgate platform will fold and latch properly as in the "in transit" position. Platform must fold smoothly and freely.
3. Check to see that hydraulic hose fittings are tight, and that the hydraulic hoses and electrical cords do not rub liftgate or other materials while cycling, UP, Down, Open & Close. Adjust as necessary by loosening fittings or clamps and adjusting its position, then re-tighten fittings or clamps.

IMPORTANT! DO NOT thin hydraulic fluid with brake fluid, and DO NOT use brake fluid in place of hydraulic fluid.



FINAL INSPECTION CHECK LIST
ALL OF THE FOLLOWING ITEMS ARE TO BE CHECKED



AND VERIFIED BEFORE INSTALLATION IS COMPLETE.

IMPORTANT WARNING

DO NOT USE LIFTGATE IF ANY OF THE BELOW ARE NOT CHECKED AND VERIFIED. IF YOU HAVE ANY QUESTIONS, CONTACT YOUR NEAREST ANTHONY DISTRIBUTOR, OR THE ANTHONY FACTORY AT...

Anthony Liftgates, Inc., 1037 W. Howard St., Pontiac, IL. 61764, 815-842-3383

Check to verify that each item has been inspected.

- Check all welds to see that they are done properly.
- Pump Reservoir is full of hydraulic oil.
- FOR GRAVITY DOWN MODELS** - Fluid level should be 1/2" from top of reservoir while liftgate platform is in the extreme lowered position.
- FOR POWER DOWN MODELS** - Fluid level should be 1/2" from the top of reservoir while platform is in the unfolded and raised position.
- All phases of liftgate operation work properly.
- Platform adjusted properly with necessary shims, if required.
- Pump Cover is closed and hasp is secured (padlock, lock pin, wired, not supplied).
- Check to see that all decals are in place and legible.
- License plate properly installed as required by law.
- Lights installed and operating properly, per FMVSS 108.
- Reflectors re-installed, if any.
- Both "Operation Instructions and Maintenance Guide" and "Installation Instructions" in vehicle.
- All pins in place and held in by their proper retainers.
- Cut-off switch installed, if so equipped.
- Operate the liftgate through its entire operational cycle several times.
- Check that the lift operates, freely and smoothly throughout the entire operating cycle, Up, Down, Open & Close.

Anthony AC Conventional Series Liftgate

General Safety Operating Instructions and Maintenance Guide

Models

AC-1600-SF

AC-2000-SF

AC-2500-SF

Anthony Liftgates, Inc.

**1037 W. Howard St.
Phone 815-842-3383**

Pontiac, IL 61764

The following is a list of **Do's** and **Don'ts** for the operation of the liftgate.

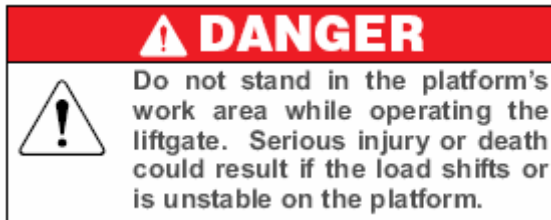

Do's

- Read and follow warning decals, operating decals, and owners manual.
- Keep all decals in place and legible and retain the owners manual in the vehicle or all warranties are void.
- Make sure the vehicle is properly and securely braked before using the liftgate.
- Keep yourself clear of all moving parts.
- Make sure the area in which the platform will open and close is clear before opening, closing, raising, or lowering the platform.
- Make sure the platform area, including the area in which loads may fall from the platform, is clear before, during, and at all times while operating the liftgate.
- Always place the load as close to the center of the platform as possible. Also position the load as close to the center of the truck's rear sill as possible.
- Only operate the liftgate with the push button or switch controls mounted on the truck body.
- Check the oil level in the hydraulic monthly, add as necessary. Change it if it is contaminated or dirty.
- Visually inspect your liftgate frequently and keep it properly adjusted. Be certain the platform is positioned correctly, not slanted away from the truck when in the raised position. Check for bent members, any cracks and/or broken welds, etc.
- Repair any damage to the liftgate to prevent accidents.
- Lock the liftgate into the storage position with the latch pin located on the "liftframe in the center of the mechanism when the liftgate is not in use. And, engaged the hooks into the "staples" on each side of the liftgate platform to hold it in the upright position while in transit.

Don'ts

- Do not overload the platform. The maximum rated capacity is based on an evenly distributed load on the platform's flat surface.
- Do not ride on the liftgate. Always stand clear of liftgate when it is operating.
- Do not allow children to play around or operate the liftgate.
- Do not allow your liftgate to be used by persons not familiar with its operation.
- Do not use your liftgate if it shows signs of abuse or fails to operate freely.
- Do not allow the motor/pump to run after the liftgate is closed, or in the up position.
- Do not use brake fluid in the hydraulic reservoir.
- Do not bounce the platform by pushing and releasing the control button/switch abruptly.
- Do not use the liftgate for anything other than its intended use of loading and unloading cargo.
- Do not operate lift trucks on or over any part of the platform.
- Do not stand under or place any object under the liftgate work area.



Operating Instructions

OPEN PLATFORM TO HORIZONTAL POSITION.

- A) Unlatch the “latch pin”, near the center of the liftgate mechanism, by twisting, then sliding it past the “latch block” welded to the radius arm.
- B) Remove the “hook and chain” from each side of the platform, streetside first.
- C) Unfold the platform, by pulling back on the platform, until in horizontal position (this is done manually).
- D) Press the “Down” switch, on the control, to lower the platform.
- E) Press the “Up” switch, on the control, to raise the platform.
- F) Load and unload cargo with the platform at either the truck floor level or the ground. Repeat step D and E to raise and lower cargo.

STORING PLATFORM FOR TRANSIT.

- A) Raise the platform to truck bed level. Fold the platform, by lifting up on the platform, until it's in the vertical position (this is done manually).
- B) Re-attach the “hook and chain” on each side of the platform, curbside first. Slip the large link of chain over the “staple” on the platform. Then, insert the hook through the “staple”. The hook should go through the bottom of the staple first.
- C) Set the “latch pin” by twisting, then sliding it past the “latch block” welded to the radius arm near the center of the liftgate.

OPERATING INSTRUCTIONS
For “**AC**” Series Conventional Liftgates

OPEN PLATFORM TO HORIZONTAL POSITION.

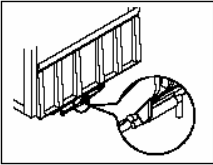

- A) Unlatch the “latch pin”, near the center of the liftgate mechanism, by twisting, then sliding it past the “latch block” welded to the radius arm.
- B) Remove the “hook and chain” from each side of the platform, streetside first.
- C) Unfold the platform, by pulling back on the platform, until in horizontal position (this is done manually).
- D) Press the “Down” switch, on the control, to lower the platform.
- E) Press the “Up” switch, on the control, to raise the platform.
- F) Load and unload cargo with the platform at either the truck floor level or the ground. Repeat step D and E to raise and lower cargo.

STORING PLATFORM FOR TRANSIT.

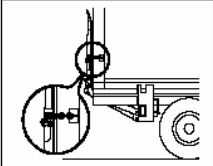

- A) Raise the platform to truck bed level.
- B) Fold the platform, by lifting up on the platform, until it's in the vertical position (this is done manually).
- C) Re-attach the “hook and chain” on each side of the platform, curbside first. Slip the large link of chain over the “staple” on the platform. Then, insert the hook through the “staple”. The hook should go through the bottom of the staple first.
- D) Set the “latch pin” by twisting, then sliding it past the “latch block” welded to the radius arm near the center of the liftgate.

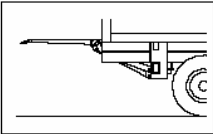

Note: If liftgate has a “Main Power Cut-off Switch” be certain to turn it “Off” when not in use to prevent unauthorized use!

Anthony Liftgates, Inc. 1037 W. Howard St. Pontiac, IL 61764

Part # A-131023

Quick Check Maintenance Guide

Monthly Inspection

SPECIAL NOTE: These AC-Series Anthony Liftgates are "Service-Free". This means that newer liftgates have lubrication-free bushings at the major pivot points which, of course, do not require lubrication. Consequently these liftgates do not have grease zerks.

1. Make sure the liftgate operates freely and smoothly throughout its entire range of movement.
2. Check for damage to the liftgate such as bent or distorted members, or any cracked weld which may have resulted from overload or abuse. Check for excessively worn parts. Replace bushings and pins if extremely worn.
3. Check all pins and pivot points. Make sure they are secured with proper retainers.
4. Make sure platform is angled upward from truck bed 1/2 to 3/4 inch when raised to bed height. See Platform Adjustment for a shimming procedure.
5. Make sure all electrical wires, switches, and connections are in good working condition and operate properly.
6. Check for oil leaks in these areas:
 - a. Hydraulic lift cylinder.
 - b. Hydraulic hoses. Replace if they show signs of leakage or excessive abrasion of the covering.
 - c. Check all hydraulic fittings for damage or leaks. Tighten fittings to stop leaks or replace if damaged.
7. Check reservoir oil level.
 - a. Gravity down models - With the platform on the ground, the oil level should be within 1/2 inch of the top of the reservoir.
 - b. Power down models – Place liftgate in the fully raised, the oil level should be within 1/2 inch of the top of the reservoir.
 - c. Fill as required with Penzoil AWX Automatic Transmission Fluid or equivalent.

IMPORTANT NOTICE

Use only Penzoil AWX Automatic Transmission Fluid or equivalent in the power unit reservoir. Do not use brake fluid.

8. Check the fluid level of the vehicle battery. Fill as required.
9. Examine all Warning, Capacity, and Operational Decals. If they are not readable they should be replaced. Decals may be obtained from Anthony Liftgates, Inc.

Platform Adjustment (adding shims)

The ramp (outboard) end of platform should be 1/2 to 3/4 inches higher than truck floor. If the outboard end of the platform is sagging, add shims as described below to raise the end. Shimming is a normal procedure as the liftgate ages and the parts become worn.

1. Position the necessary amount of "shim plates" in the contact area between the cam plates and platform.

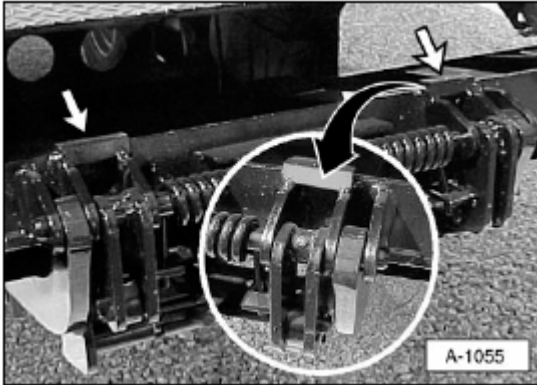

Add shims to this area to eliminate sagging.

2. Weld the steel shim plates to the blocks on platform.
3. When the platform is lowered to the ground, it should touch at the lift arm end and at the ramp end.

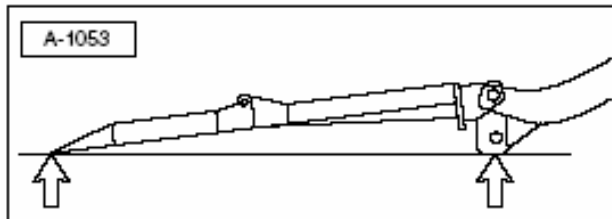

Liftgate should contact the ground at these two locations.