

ANTHONY LIFTGATES, INC.

INSTALLATION AND OPERATION MAINTENANCE & TROUBLESHOOTING

For AST and ATU Model Tuckunder Liftgates

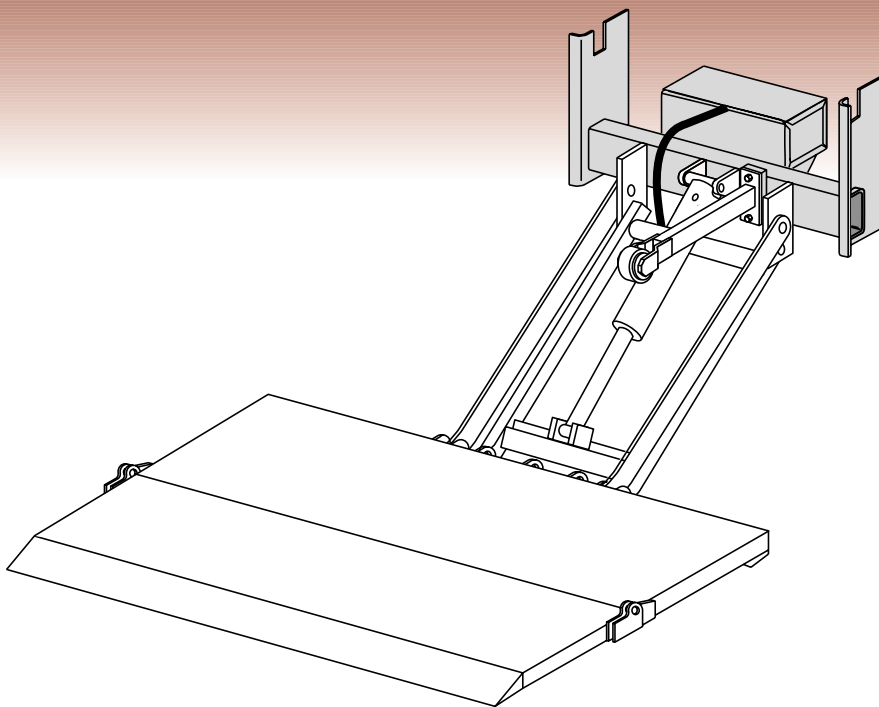

MODELS

AST-1500-SF

AST-2000-SF

AST-2500-SF

AST-3000-SF

ASTL-1800-SF

ASTL-2500-SF

ATU-1800-SF

ATU-2500-SF

ATU-3000-SF

ATU-3500-SF

ATU-1800LB-SF

ATU-2500LB-SF

ANTHONY
LIFTGATES, INC.®

Anthony Liftgates, Inc.

1037 W. Howard Street • P.O. Box 615 • Pontiac, IL 61764-0615

Ph: 815.842.3383 • Fax: 815.844.3612 • Toll Free: 800.482.0003

www.anthonyliftgates.com

Troubleshooting Section

Troubleshooting Guide

Troubleshooting Chart		
Problem	Possible Cause	Possible Solution
Motor does not run when control switch is activated.	Cab cut-off switch.	Turn switch to ON position.
	Dead battery.	Make sure battery is fully charged. Check for loose or corroded battery connections. Replace or recharge battery.
	Circuit breaker.	Reset or replace circuit breaker.
	10 Amp fuse in power unit box.	Replace, if fuse is blown. If problem continues, check for shorts in the electrical system.
	Control box switch.	Check switch using Checking Control Switch procedure in Maintenance section.
	Motor start solenoid.	Check solenoid using the procedure in the Maintenance section.
	Optional power cut-off solenoid.	Check solenoid using the procedure in the Maintenance section.
	Battery cable.	Connect motor directly to a spare battery using the procedure in the Maintenance section.
	Motor.	If the motor is determined to be bad, it should be replaced. Bad motors are typically caused by weak batteries (low voltage), loose connections, corrosion, or a poor ground.
	Circuit breaker.	Reset.
	If liftgate is installed on a semi trailer make sure the battery wire is two gauge or heavier. Smaller wires can reduce the voltage, resulting in motor failures.	
If the motor does not operate in freezing conditions, make sure the motor housing does not contain water.		

Troubleshooting Chart (continued)

Problem	Possible Cause	Possible Solution
Motor runs, but liftgate will not open or lower to the ground.	Structural damage. Check clearance between platform and dock bumpers.	Fix damage. Replace worn parts.
	Latch pin.	Slide the latch pin to the open position.
	Control switch box.	Check DOWN terminal using the procedure in the Maintenance section.
	Lowering valve solenoid.	Check the solenoid using the procedure in the Maintenance section.
	Lowering valve cartridge.	Check, remove, and clean valve cartridge using the procedure in the Maintenance section.
	Flow control valve.	Remove flow control valve and hook hydraulic hose directly to the cylinder. If the cylinder operates properly, replace the valve.
Motor runs, but platform will not raise will not raise rated capacity, or raises, but drifts down when control switch is released.	Load capacity has been exceeded.	Verify load capacity and adjust load weight.
	Structural damage.	Replace damaged parts.
	Low fluid level.	Fill reservoir.
	Low Voltage.	Inspect the battery connection terminals and check the battery's Voltage (9 Volts minimum).
	Lowering valve.	Solenoid or cartridge may need cleaning or replacement. See Maintenance section.
	Bad piston seals.	See Maintenance section for Checking Cylinder for Leakage.
	Pump relief valve needs adjusted.	See Maintenance section for Checking and Adjusting System Pressure.
Hydraulic pump is worn.	Replace hydraulic pump.	
Sagging platform.	Normal wear. section for Platform Adjustment.	Add shims to platform. See Maintenance
	Bushing wear where lift arms connect to platform.	Replace bushings.
	Structural damage.	Replace worn parts.

Troubleshooting Chart (continued)

Problem	Possible Cause	Possible Solution
Foaming oil.	Air in the hydraulic hose(s).	Check oil level in reservoir.
	Broken or loose fluid return tube.	Remove the oil reservoir and make sure the return tube is below the oil level. If the tube has turned or fallen out, reinstall it into the pump housing. Use a center punch to "stake" the tube into position.
Hydraulic fluid is leaking from packing gland.	Loose packing gland nut.	See Maintenance section for Checking Cylinder for Leakage.
Latch pin is broken or bent.	Operator has lowered platform without releasing latch pin.	The latch pin is only used to prevent the liftgate from opening due to a pressure leak or pressure bleed-off over an extended period of time. Always release latch before opening liftgate.
Liftgate raises truck when lowered to the ground.	Power down system pressure is set too high.	See Maintenance section for Checking and Adjusting System Pressure.
Liftgate will not open.	Platform operating area is not clear.	Clear platform operating area.
	Pin will not slide free.	Activate the "UP" switch and raise the liftgate to the fully stored position. Open the latch pin free.
Platform lowers extremely slow.	Low oil level on power down models.	Fill reservoir.
	Improper oil in hydraulic reservoir.	See Monthly Inspection.
	Bushing wear where lift arms connect to platform.	Replace bushings.
	Damaged or kinked hydraulic hose.	Repair or replace.
	Cylinder rod is scored, pitted, or bent.	Repair or replace.
	Flow control valve.	Remove flow control valve and hook hydraulic hose directly to the cylinder. If the cylinder operates properly, replace the valve.
	Lowering valve.	Solenoid or cartridge may need cleaning or replacement. See Maintenance section.
Platform raises partially and stops.	Load capacity has been exceeded.	Verify load capacity and adjust load weight.
	Structural damage.	Replace damaged parts.
	Low Voltage.	Recharge battery (if less than 9 volts).
	Low pressure.	Refill reservoir. Check pump and motor.
Platform will not lower.	Platform operating area is not clear.	Clear area.
	Structural damage.	Replace damaged parts.
	Low Voltage.	Recharge battery (if less than 9 volts).
	Lowering valve.	See Maintenance section.
	Hydraulic pump and motor.	Replace power unit.



Anthony Liftgates, Inc.
1037 W. Howard Street • P.O. Box 615 • Pontiac, IL 61764-0615
Ph: 815.842.3383 • Fax: 815.844.3612 • Toll Free: 800.482.0003
www.anthonyliftgates.com
